

DSECONTROL[®] MONITORING WITH INTELLIGENCE.



DSE7310 & DSE7320

AUTO START & AUTO MAINS FAILURE CONTROL MODULES (COMMUNICATIONS & EXPANSION)



The DSE7310 and DSE7320 are control modules for single gen-set applications. The modules have been developed from the successful DSE5310 and DSE5320 Series and incorporate a number of advanced features to meet the most demanding on-site applications.

The DSE7310 is an Automatic Start Control Module and the DSE7320 is an Auto Mains (Utility) Failure Control Module. Both modules have been designed to start and stop diesel and gas generating sets that include electronic and non-electronic engines. The DSE7320 includes the additional capability of being able to monitor a mains (utility) supply.

Both modules include USB, RS232 and RS485 ports as well as dedicated DSENet[®] terminals for expansion device connectivity.

The modules are simple to operate and feature a user-friendly menu layout for improved clarity. Enhanced features include a real time clock for enhanced event and performance monitoring, ethernet communications for low cost monitoring, mutual standby (DSE7310 only) to reduce engine wear and tear and preventative maintenance features to detect engine part faults prior to a major problem occurring.

FEATURES

- Backed up real time clock
- 132 x 64 pixel LCD display
- Configurable display languages
- Five-key menu navigation
- Fully configurable via PC software
- LED and LCD alarm indication
- Engine exercise mode
- Configurable start & fuel outputs
- kWh monitoring
- Automatic load transfer
- Eight configurable digital inputs
- Six configurable outputs
- Configurable timers and alarms
- Modbus RTU
- Magnetic pick-up
- Selected front panel programming
- Multiple date and time exercise scheduler
- SMS messaging (additional external modem required)
- Power save mode
- User selectable RS232 & RS485 communications
- DSENet[®] compatible
- Ethernet communications via DSE860/865
- Multiple date and time maintenance scheduler
- Configurable display pages
- Programmable load shedding/acceptance
- Preventative maintenance
- kW overload protection
- Unbalanced load protection
- Flexible sender input
- Configurable SCADA output page
- True dual mutual standby with load balancing timer (DSE7310 only)
- Fan control for additional cooling
- 'Protections Disabled' facility
- Fuel usage monitoring and low fuel alarm
- Support for up to three remote display units
- Automatic sleep mode
- Easy access, configurable diagnostics page shows summary of output states
- Improved programmable event log (250) showing date and time
- Manual fuel pump control
- 3 alternative configurations
- Multiple date and time scheduler
- 3 Programmable Maintenance alarms with comms alert
- Customisable status screens
- Low fuel level alarm delay
- Charge alternator fail warning and shutdown alarms with user programmable delay
- Independent Earth fault trip
- Sleep mode
- Load switching (Load shedding and dummy load outputs)
- Manual speed trim (on CAN engines that support this feature)
- Additional display screens to help with modem diagnostics
- Security levels – PC software has password system to control access to PC software features
- Operator configurable virtual LEDs visible in SCADA

NEW FEATURES

- Additional programmable logic
- Improved modem diagnostics
- Remote control sources (10) can be accessed via SCADA
- Additional electrical trip options
- Additional start delay functions
- Oil pressure values from additional engines
- Front panel editing of scheduler
- Displays kW as % of rated kW setting

SPECIFICATION

DC SUPPLY

CONTINUOUS VOLTAGE RATING
8V to 35V Continuous

CRANKING DIP PROTECTION
Able to survive 0V for 50mS, providing supply was at least 10V before dropout and supply recovers to 5V. This is achieved without the need for internal batteries

CHARGE FAIL/ EXCITATION
0V to 35V fixed power source 2.5W

MAXIMUM STANDBY CURRENT
160mA at 12V 80mA at 24V

MAXIMUM OPERATING CURRENT
340mA at 12V 160mA at 24V

ALTERNATOR INPUT

RANGE
15V - 333V (L-N) 50Hz - 60Hz
(Minimum 15V AC Ph-N)

ACCURACY
1% of full scale true RMS sensing

SUPPORTED TOPOLOGIES
3 phase 4 wire
3 phase 3 wire
3 phase 4 wire Delta
Single phase 2 wire
2 phase 3 wire L1 & L2
2 phase 3 wire L1 & L3

MAINS/UTILITY INPUT (DSE7320 ONLY)

RANGE
15V - 333V (L-N) 50Hz - 60Hz
(Minimum 15V AC Ph-N)

ACCURACY
1% of full scale true RMS sensing

SUPPORTED TOPOLOGIES
3 phase 4 wire
3 phase 3 wire
3 phase 4 wire Delta
Single phase 2 wire
2 phase 3 wire L1 & L2
2 phase 3 wire L1 & L3

CT'S

BURDEN
0.5VA

PRIMARY RATING
1A - 8000A (user selectable)

SECONDARY RATING
1A or 5A secondary (user selectable)

ACCURACY OF MEASUREMENT
1% of full load rating

RECOMMENDATIONS
Class 1 required for instrumentation
Protection class required if using for protection

SPECIFICATION

MAGNETIC PICKUP

VOLTAGE RANGE

+/- 0.5V minimum (during cranking) to 70V peak

FREQUENCY RANGE

10,000 Hz (max)

OUTPUTS

OUTPUT A (FUEL)

15 Amp DC at supply voltage

OUTPUT B (START)

15 Amp DC at supply voltage

OUTPUTS C & D

8 Amp 250V (Volt free)

AUXILIARY OUTPUTS E,F,G,H

2 Amp DC at supply voltage

DIMENSIONS

OVERALL

240mm x 181.1mm x 41.7mm
9.4" x 7.1" x 1.6"

PANEL CUT-OUT

220mm x 160mm
8.7" x 6.3"
Max panel thickness 8mm (0.3")

ENVIRONMENTAL TESTING STANDARDS

ELECTRICAL SAFETY

BS EN 60950
Safety of Information Technology Equipment,
including Electrical Business Equipment

ELECTRO MAGNETIC COMPATIBILITY

BS EN 61000-6-2
EMC Generic Immunity Standard for the
Industrial Environment
BS EN 61000-6-4
EMC Generic Emission Standard for the
Industrial Environment

TEMPERATURE (OPERATING)

BS EN 60068
Test Ab to +70°C 60068-2-2 Hot
Test Ab to -30°C 60068-2-1 Cold

VIBRATION

BS EN 60068-2-6
Ten sweeps in each of three major axes
5Hz to 8Hz @ +/-7.5mm, 8Hz to 500Hz @ 2g

HUMIDITY

BS 2011 part 2.1 60068-2-30
Test Cb Ob Cyclic
93% RH @ 40°C for 48 hours

SHOCK

BS EN 60068-2-27
Three shocks in each of three major axes
15gn in 11ms

BENEFITS

- 132 x 64 pixel ratio makes information easy to read
- Real time clock provides accurate event logging
- PC software is license free
- Set maintenance periods can be configured to maintain optimum engine performance
- Ethernet communications provides advanced remote monitoring at low cost
- Modules can be integrated into building management systems
- Preventative maintenance avoids expensive engine down time
- Advanced PCB layout ensures high reliability
- Robust design
- Extensive performance monitoring

OPERATION

The modules are operated via the START, STOP, AUTO and MANUAL soft touch membrane buttons on the front panel. The DSE7320 also has a TEST button. Both modules include load switch buttons. The main menu system is accessed using the five navigation buttons to the left of the LCD display.

CONFIGURATION

The modules can be configured using the front panel buttons or by using the DSE Configuration Suite PC software and a USB lead.

COMMUNICATIONS

The DSE7310 & DSE7320 have a number of different communication capabilities.

SMS Messaging

When the module detects an alarm condition, it has the ability to send an SMS message to a dedicated mobile number (s), notifying an engineer of the exact time, date and reason why the engine failed (GSM Modem and SIM Card required).

Remote Communications

When the module detects an alarm state, it dials out to a PC notifying the user of the condition (Modem required).

Remote Control

The module can be controlled remotely using either a GSM Modem, Ethernet via DSE860/865 or via RS485. Using a modem allows the module to be controlled from any distance. Using RS485 limits the distance to 1km (0.6 miles).

Building Management

The module has been designed to be integrated into new and existing building management systems, using RS485.

PC Software

The module has the ability to be configured and monitored from a remote PC, using the PC software and a USB lead.

INPUTS & OUTPUTS

Analogue inputs are provided for oil pressure, coolant temperature and fuel level. These connect to conventional engine mounted resistive sensor units to provide accurate monitoring and protection facilities. They can also be configured to interface with digital switch type inputs for low oil pressure and high coolant temperature shutdowns. Eight user configurable digital inputs are also included, plus one flexible sender.

Outputs are provided for fuel solenoid, start solenoid and six additional configurable outputs. On these configurable outputs a range of different functions, conditions or alarms can be selected.

INSTRUMENTATION

The modules provide advanced metering facilities, displaying the information on the LCD display. The information can be accessed using the five-key menu navigation to the left of the display.

DSENET®

DSENet® is a collection of expansion modules that have been created to work with DSENet® compatible control modules. DSENet® allows up to 20 different expansion devices to be used at a time. The expansion modules available are:

- DSE2157 Relay Output Expansion Module
- DSE2130 Input Expansion Module
- DSE2548 Annunciator Module Remote Display Module
- DSE2510 Remote Display
- DSE2520 Remote Display

EVENT LOG

The module includes a comprehensive event log that shows the most recent 250 alarm conditions and the date and time that they occurred. This function assists the user when fault finding and maintaining a generating set.

ELECTRONIC ENGINE COMPATIBILITY

- CAT
- Cummins
- Deutz
- John Deere
- MTU
- Perkins
- Scania
- Volvo
- IVECO
- Generic
- Plus additional manufacturers

RELATED MATERIALS

TITLE	PART NO'S
DSE7xxx Manual	057-074
DSE72xx/73xx PC Software Manual	057-077
DSE2130 Data Sheet	053-060
DSE2157 Data Sheet	053-061
DSE2548 Data Sheet	053-062
DSE860/865 Data Sheet	055-071
DSE2510/20 Data Sheet	055-074

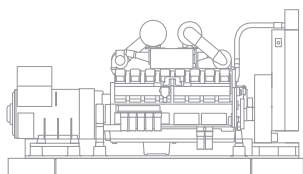

ELECTRONIC ENGINE CAPABILITY

7310	7320
<p>Generator Instruments Volts, Hz, Amps, kW, kVA, Pf, kWh, kVAr, kVArh, KVArh</p> <p>Engine Instruments RPM, Oil Pressure, Coolant Temperature, Hours Run, Charging Voltage, Battery Volts.</p> <p>Electronic Engines Enhanced Instrumentation and Engine ECU diagnostics via electronic engine interface.</p>	<p>Generator Instruments Volts, Hz, Amps, kW, kVA, Pf, kWh, kVAr, kVArh, KVArh</p> <p>Engine Instruments RPM, Oil Pressure, Coolant Temperature, Hours Run, Charging Voltage, Battery Volts.</p> <p>Electronic Engines Enhanced instrumentation and Engine ECU diagnostics via electronic engine interface.</p> <p>Mains/Utility Instruments Volts, Frequency, Amps (optional when CT's are fitted load side of the line)</p>

DSE7310 & DSE7320

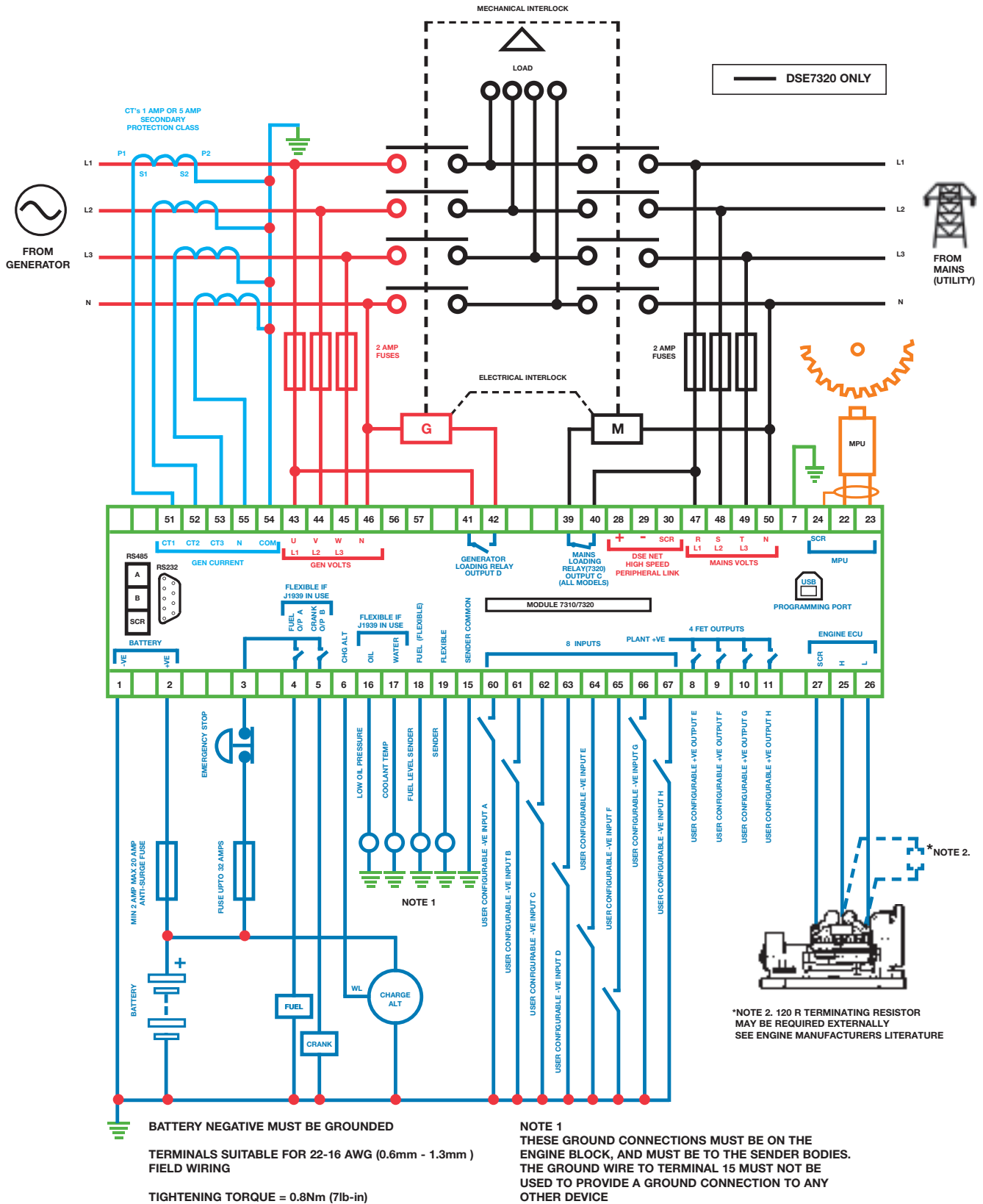

DEEP SEA ELECTRONICS PLC

Highfield House
Hunmanby Industrial Estate
Hunmanby, North Yorkshire
YO14 0PH England

TELEPHONE

+44 (0)1723 890099

FACSIMILE

+44 (0)1723 893303

EMAIL

sales@deepseapl.com

WEBSITE

www.deepseapl.com



Registered in England & Wales No.01319649

VAT No.316923457

DEEP SEA ELECTRONICS INC

3230 Williams Avenue
Rockford
IL 61101-2668 USA

TELEPHONE

+1 (815) 316 8706

FACSIMILE

+1 (815) 316 8708

EMAIL

sales@deepseausa.com

WEBSITE

www.deepseausa.com

YOUR LOCAL DISTRIBUTOR.

DEEP SEA ELECTRONICS PLC maintains a policy of continuous development and reserves the right to change the details shown on this data sheet without prior notice. The contents are intended for guidance only.

This data sheet is printed on 9lives 55 Silk, which is produced with 55% recycled fibre from both pre and post-consumer sources, together with 45% virgin ECF fibre.

